

SPECIFICATIONS:

WEIGHT:
 BATTERY PACK (7AH): 2.15 POUNDS (0.98 KILOGRAMS)
 BATTERY PACK (10AH): 2.15 POUNDS (0.98 KILOGRAMS)

MATERIALS:
 ALUMINUM
 POLYCARBONATE
 POLYPROPYLENE LABELS
 NEOPRENE GASKETS
 STAINLESS STEEL HARDWARE

ENVIRONMENTAL:
 OPERATING (CHARGE) TEMPERATUE: 32°F (0°C) - 113°F (45°C)
 OPERATING (DISCHARGE) TEMPERATUE: -4°F (-20°C) - 140°F (60°C)
 STORAGE TEMPERATURE: 14°F (-10°C) - 95°F (35°C)

ELECTRICAL:
 NOMINAL CAPACITY: 7AH(105Wh) - 10AH(150Wh)
 NOMINAL VOLTAGE: 15V
 DISCHARGE VOLTAGE: 11.6V ± 0.2V
 CHARGE VOLTAGE: 16.8V ± 0.2V
 INTERNAL RESISTANCE 7AH (EST): ≤13mΩ
 INTERNAL RESISTANCE 10AH (EST): ≤10mΩ
 MAX CONTINUOUS DISCHARGE 7AH: 3.5 AMPS
 MAX CONTINUOUS DISCHARGE 10AH: 5.0 AMPS
 BATTERY POS(+): .250(6.35mm) GOLD-PLATED TAB TERMINALS(2)
 BATTERY NEG(-): .250(6.35mm) GOLD-PLATED TAB TERMINALS(2)
 OUTPUT PROTECTION: SHORT CIRCUIT/OVER CURRENT (INTERNAL RESETTABLE FUSE)
 INTERNAL CELL BALANCING
 OVER TEMP SHUT DOWN, AUTO RESET

MOUNTING:
 MOUNTING SCREWS: #8-32 OR EQUIVALENT, 18-8 STAINLESS STEEL



PREC

TABULATED P/N DESRIPTION	
DPI P/N	BATTERY CELLS
49-15LNMC04A07-00	7AH LITHIUM CELLS
49-15LNMC04A10-00	10AH LITHIUM CELLS

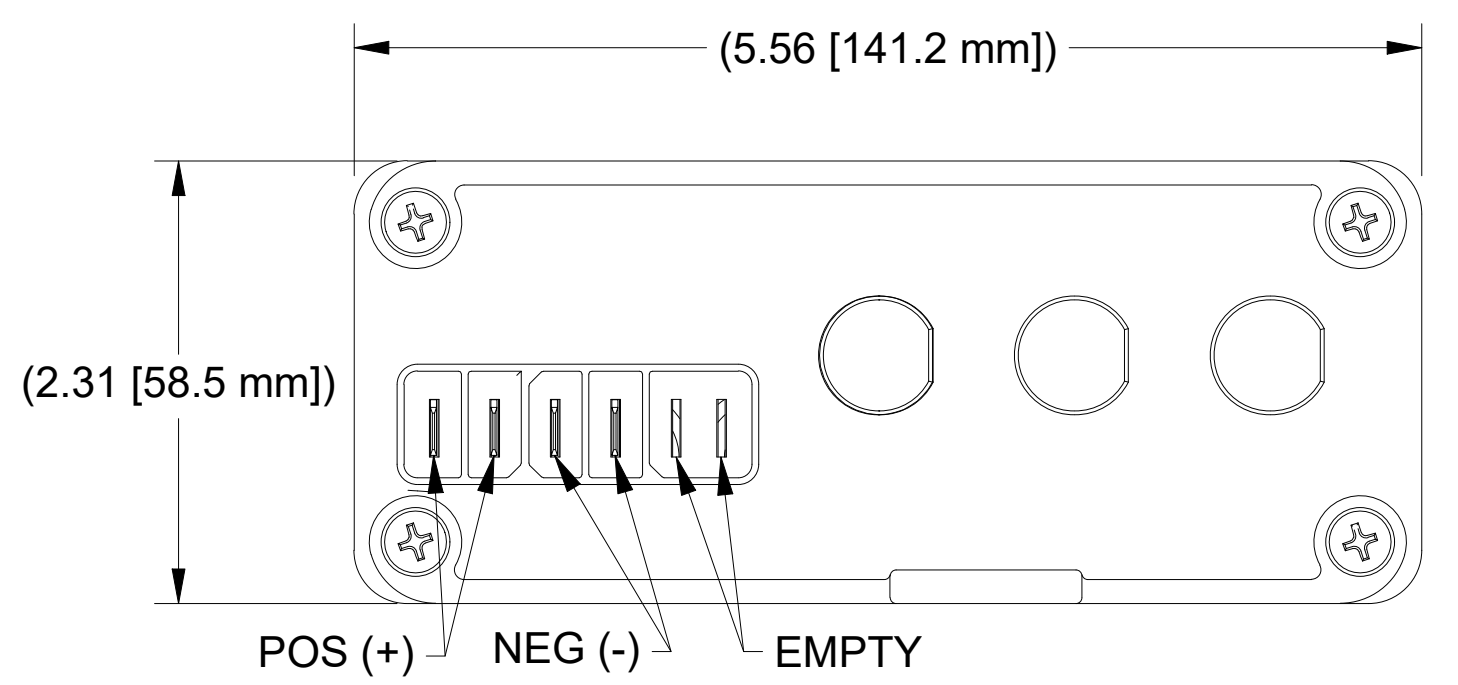
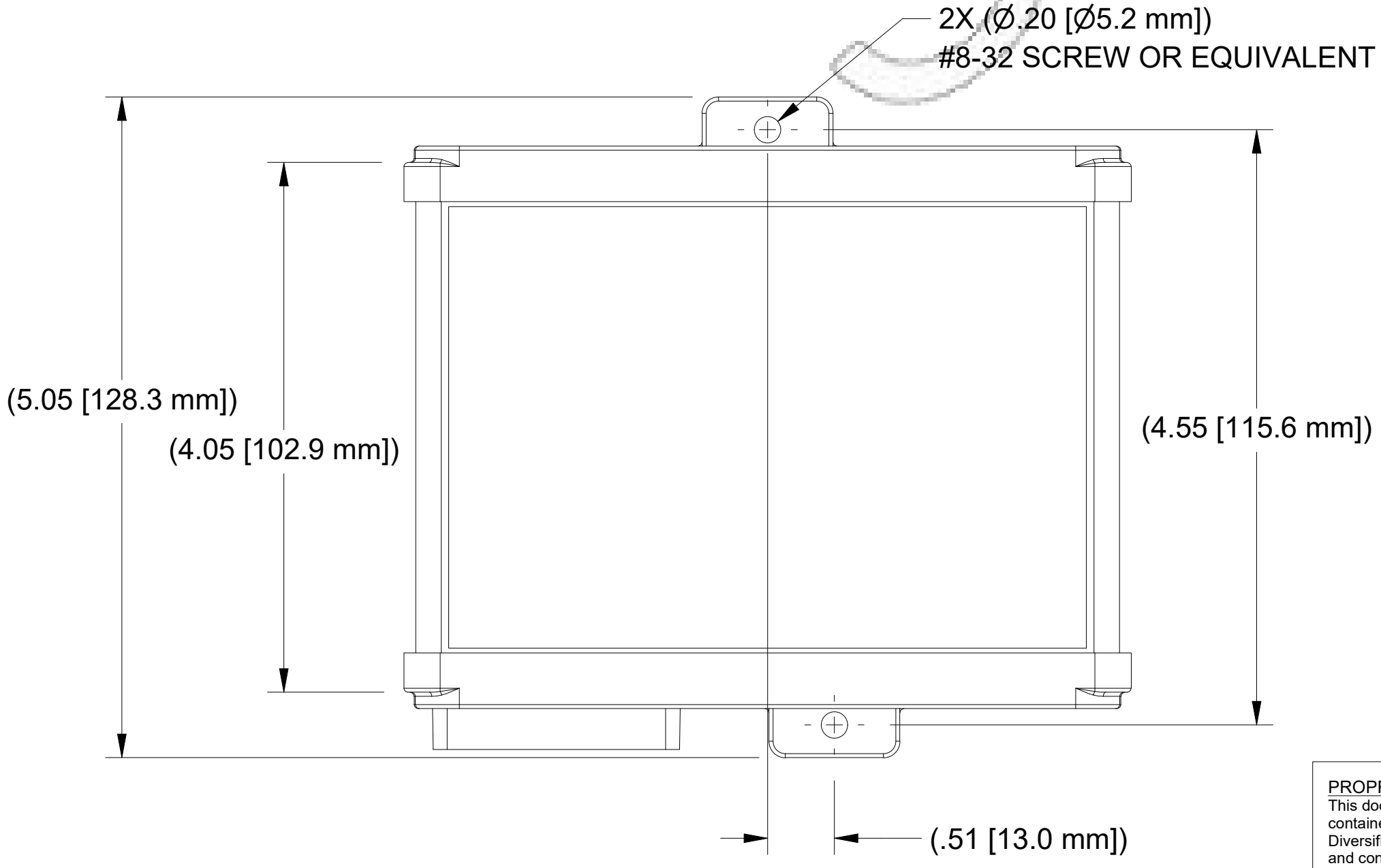

NOTES:
 1. DIMENSIONS ARE FOR REFERENCE ONLY.

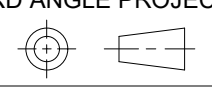
PROPRIETARY AND CONFIDENTIAL This document and the information contained within is the property of Diversified Power International (DPI), LLC and contains Confidential and Proprietary Information which may not be reproduced in any form and may not be disclosed to any third party; and may not be used for any purpose that is contrary to it's intended purpose and use without the express written consent of DPI.	TOLERANCES (UNLESS NOTED): INCHES [millimeters]: 3 PLACES: ± .005 [.13 mm] 2 PLACES: ± .02 [.5 mm] ANGULAR: ± 1/2°	SIGNATURES DRAWN: NGB CHECKED: AFM APPROVED: AFM	DATE 11/6/2023 11/6/2023 11/6/2023	TITLE LITHIUM BATTERY PACK  DIVERSIFIED POWER INTERNATIONAL, LLC 414 CENTURY COURT PINEY FLATS, TN 37686 PHONE: 423-538-9002		
	THIRD ANGLE PROJECTION 	NEXT ASSY: N/A USED ON: N/A	SIZE C		DWG NO 49-15LNMC04xxx-xx	REV R00
	CAD DRAWING: DO NOT SCALE	SHEET 1 OF 1	SIZE C		DWG NO 49-15LNMC04xxx-xx	REV R00
			SHEET 1 OF 1		DWG NO 49-15LNMC04xxx-xx	REV R00